

V6 Series USER'S MANUAL

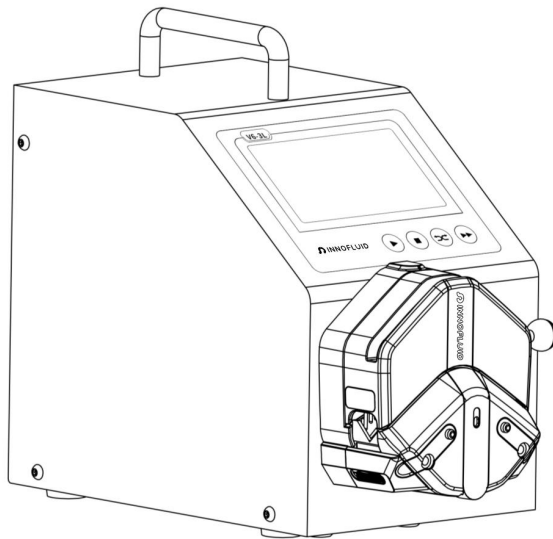



Note:

- Please read the manual carefully before operating the product.



Warning:

- Tubing may have crack due to wear. It results in the overflow of fluid from tubing. In that time human body and instruments may be harmed. So users must check frequently and change tubing in time.
- Connect the power cord to the wall socket, and avoid using electric extension cords.
- If the power cord or plug shows wear and/or other damage, please disconnect from socket by pulling the plug, not the wire and contact service.
- In the following circumstances, turn off the power supply and disconnect the plug by holding the plug itself, not the wire:
 - 1.Fluid has splashed onto the pump.
 - 2.Pump needs maintenance or repair.
- The power socket should be equipped with a ground wire and properly grounded.

Note: Ensure that the foot pedal switch and other external control plugs are connected or disconnected only when the power is off, to prevent damage.

Table of contents

1. Product Overview - 1 -

2. Product Appearance - 1 -

3. Keyboard Instruction - 2 -

4. Operation Interface Structure - 2 -

5. Main Functions Operation Process - 17 -

6. External Control Interface Instruction - 20 -

7. Technical Specification - 26 -

8. Main Functions and Features - 27 -

9. Dimension Drawing - 28 -

10. Maintenance - 30 -

11. Warranty and After-Sales Service - 31 -

1. Product Overview

V6 series products are the flow measurement type intelligent peristaltic pump, with 4.3 inch color touch screen control, animation shows working state. The flow data, setting parameters and system settings are displayed in the same screen. With intelligent calibration and on-line micro adjusting function, four kinds of measurement modes: Fixed volume measurement, volume dispensing, speed dispensing, timer start and stop. This product can load different pump heads, multiple external methods are optional. It is ideal choice for laboratory, equipment supporting and industrial production.

V6 series include many product types: V6-3L, V6-6L, V6-12L.

Suitable for many pump heads: EasyPump, YZ1515x, YZ2515x; DZ25-3L, DZ25-6L, DY15, DY25, YZ35, KD.

2. Product Appearance

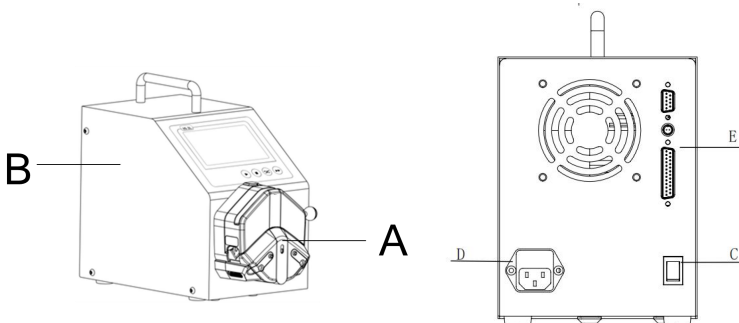

A—Pump Head

B—Drive

C—Power Switch

D—Power Socket

E—External Control

3. Keyboard Instruction

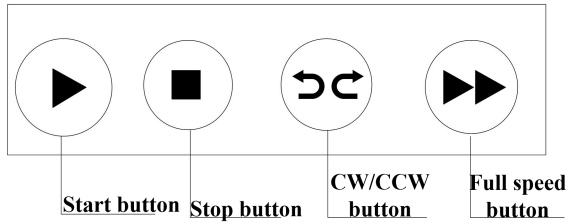

- **Start Button:** Press this button, the motor starts running. When fixed volume measurement or dispensing function are on, press this button, the pump will start work with the function, clicking this button again will pause current operation.
- **Stop Button:** Press stop button, pump stops working. Forbidden buttons in the main interface can be used. Press and hold this button while turning on the device power to initialize the device. All parameters will be lost.
- **CW/CCW Button:** Press this button once, the motor will change running direction once. When the fixed volume measurement or dispensing are on, this button does not work.
- **Full Speed Button:** Pressing this button while the device is in the stop state or during transfer mode will cause the device to run at maximum speed. This can be used for cleaning the tubing or rapid liquid filling.

4. Operation Interface Structure

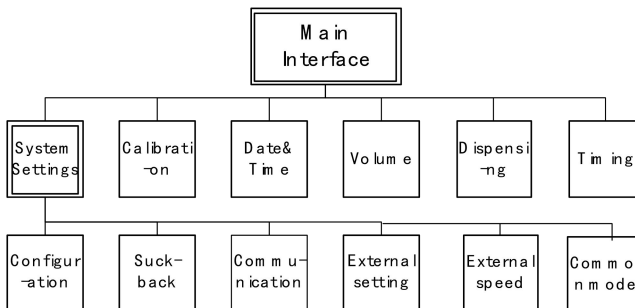

V6 Series Operation Interface Instruction

4.1 Boot Screen

After power on the system, enter the Boot screen. Click anywhere or wait for 2.5 seconds it will enter the English main operation interface automatically.

4.2 Main Interface

Main interface composition as below:

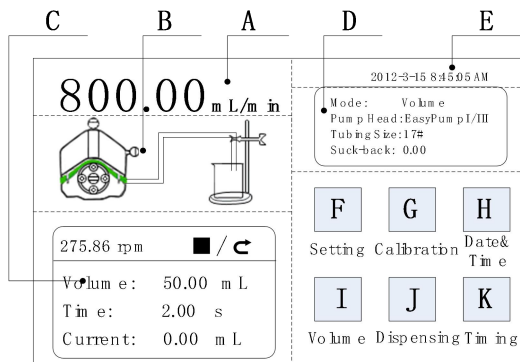

A. Speed/Flow Rate Display: In flow rate mode, the currently set flow rate is displayed, and the speed is shown in box C. In speed mode, the currently set speed is displayed, and the flow rate is shown in box C. Click here to modify the current flow rate or speed. When timed dispensing is enabled, this function is disabled, and the flow rate or speed cannot be modified.

B. Real-time Dynamic Display: Real-time display of the current running status, dynamic display of the running results.

C. Real-time Parameter Display: Displays the current operating status and set parameters. When the Volume function is enabled, it shows the Volume parameters. When the dispensing function is enabled, it shows the dispensing parameters. When both functions are turned off, display transmission mode parameters.

D. Setting Parameter Display: Displays modes, pump head models, tubing sizes and suck back angle.

E. Date and Time Display: Displays the current date and time, you can change it

in the system settings. When it displays an alarm clock on the right side, it means the timer start and stop function had turned on.

F. System Settings Button: Click this button, set up other parameters.

G. Flow Calibration Button: Click this button enter the flow rate calibration interface.

H. Date & Time Button: Click this button enter set up current date and time interface.

I. Volume Button: Click this button, enter the fixed volume measurement interface.

J. Dispensing Button: Click this button, enter dispensing interface.

K. Timing Button: Click this button, enter timer start and stop interface.

4.3 Numeric Keypad Input Interface

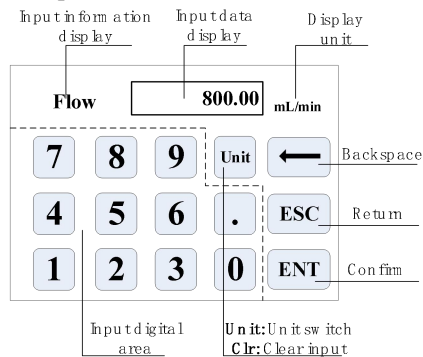

- **Input Information Display:** The information displayed is the current operation object.
- **Input Data Display:** Display the current input data, range is 0.01-9999.
- **Unit Display:** Display input units when input flow rate or volume.
- **Input Digital Area:** Numeric keypad.
- **Unit/Clr Button:** When input flow rate or volume, this button is unit switch, you can choose different units. When it is Clr, you can clear the current input data.
- **Backspace Button:** Delete an input digital.

- **ESC Button:** Cancel the current input, back to previous interface.
- **ENT Button:** Confirm the current input.

4.4 The Basic Configuration Interface

The basic configuration interface:

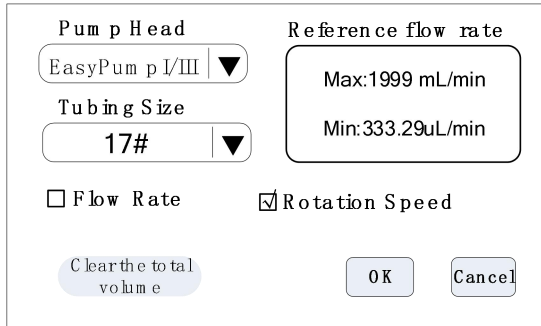

Transfer

Click the pump head and tubing size to choose the pump head and tubing.

Reference flow rate display the max. and min. flow rate with the current pump head and tubing.

Note that: When the pump comes with two pump heads, the output of two pump heads are connected to one channel, then you will need to choose 2* pump head model; In other cases, you need to choose a separate pump head model.

For example, the pump comes with two EasyPumpI, the output of two pump heads are connected to one channel, then when choose pump head need to select 2*EasyPumpI, as in below picture: 

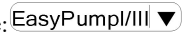
In other cases, such as: the pump comes with one pump head EasyPumpI, or with two EasyPumpI use as two channels, or with 3 or 4 EasyPumpI pump heads, need to select single pump head EasyPumpI, as in below picture: 

In the transfer mode diagram above, click the Flow rate mode or Speed mode button to choose the working mode. When you choose the flow rate mode, the flow rate is adjustable, the speed will change with the flow rate. When you choose the rotation speed mode, the speed is adjustable, the flow rate will change with the rotating speed. Click the confirm button when you had finished choosing parameter then back to the main interface.

Click the "Clear the total volume" button to manually reset the total transfer amount, and the total running time will also be reset to zero.

Pum p Head EasyPum p I/III ▼	Refe rence flow ra te M ax:1999 m L/m in M in:333.29uL/m in
Tu b in g Size 17# ▼	
<input type="checkbox"/> Flow rate	<input checked="" type="checkbox"/> Rotation Speed
<input type="button" value="OK"/> <input type="button" value="Cancel"/>	

Vo lum e

In the Volume mode diagram above, click the Flow Rate mode or Rotation Speed mode button to choose the working mode. When you choose the flow rate mode, the flow rate is adjustable, the speed will change with the flow rate. When you choose the speed mode, the speed is adjustable, the flow rate will change with the rotating speed. Click the confirm button when you had finished choosing parameter then back to the main interface.

Pum p Head EasyPum p I/III ▼ Tub ing Size 17# ▼ <input type="checkbox"/> Show the current speed <input checked="" type="checkbox"/> Show the total num bers Clear the total num bers	Reference Flow Rate Max:1999 m L/m in M in :333.29uL/m in OK Cancel
--	---

Speed dispensing

In the Speed dispensing mode diagram above, clicking to display the current speed will show the current speed in the upper-left corner of the main interface. Clicking to display the total number of distributions will show the total number of dispensing in the upper-left corner of the main interface. Click the "Clear the total numbers" button to manually reset the total dispensing count. The maximum count is 9999, after which it will automatically reset to zero.

Pum p Head EasyPumpI/III ▼ Tub ing Size 17# ▼ <input type="checkbox"/> Show the current Dis. VoL <input checked="" type="checkbox"/> Show the total num bers Clear the total num bers	Reference Flow Rate Max:1999 mL/min Min:333.29uL/min OK Cancel
---	--

Volume dispensing

In the volume dispensing mode diagram above, clicking to display the current filling volume will show the current speed in the upper-left corner of the main interface. Clicking to display the total number of distributions will show the total number of

dispensing in the upper-left corner of the main interface. Click the "Clear the total numbers" button to manually reset the total dispensing count. The maximum count is 9999, after which it will automatically reset to zero.

4.5 Back Suction Angle Interface

The back suction angle interface as below:

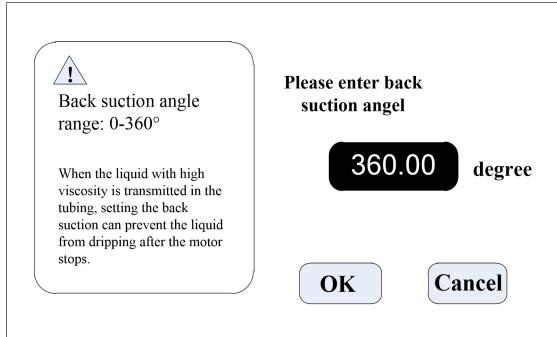

Click the **System Settings** button in the main interface, then click **Back suction** button to enter the back suction angle setting interface. Click **angle** button, pop up the numeric keyboard for inputting the suction angle, enter back suction angle then click **OK**. If click the **Cancel** button, it will back to the system settings main interface.

4.6 Communication Setting Interface

The communication setting interface as the follow picture shows

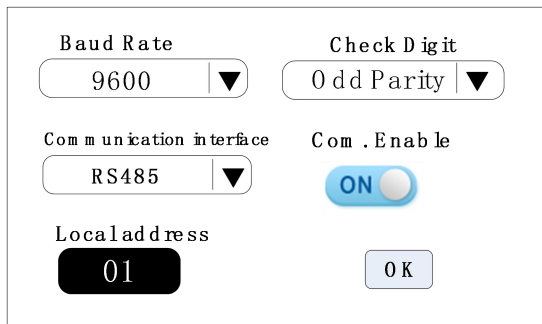

Click **System Settings** button in the main interface, then click **Communication** button to enter communication settings interface.

This pump support MODBUS——RTU Mode. Please select baud rates and communication interface (RS485/RS232). Click **Slave No.** button to enter peristaltic pump address No.(range:1-32), select communication enable is **ON**. Then this pump can communicate with master, receiving master signal.

NOTE: Peristaltic pump only receives communication control when in the main interface, it's out of communication control when in other interface.

4.7 External Control Setting Interface

External Control Setting Interface as below:

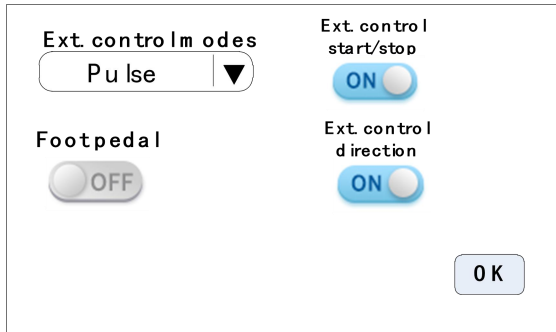

Click **System Settings** button in the main interface, then click **External control** to enter **External Settings** interface.

- a. **There are two types of signals for external control motor start/stop and direction: Level mode and Pulse mode.** Connection interface refer to the external control interface instruction.
- b. **Various external control modes are independently set on switches, which will only work after the corresponding external control function is turned on.**

4.8 External Control Speed Setting Interface

External control speed as the follow picture shows

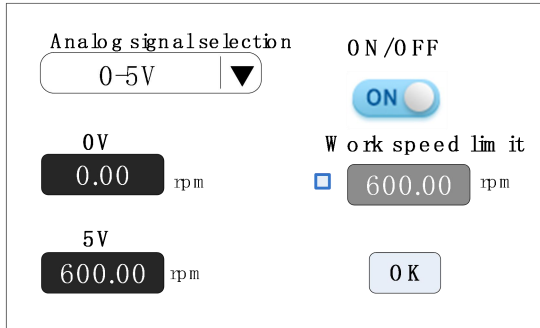

Click **System Settings** button in the main interface, then click **External Speed Control** button to enter external speed control settings interface.

According with external input signal to set the analog signal, **0-5V**, **0-10V** or **4-20mA**. Between analog signal voltage range and motor speed, there is linear relationship. (when the working speed limit is off).

After turning on the maximum working speed limit, the motor speed will be limited. For example: if 0V to 0rpm, 5V to 600rpm (then 2.5V should be 300rpm). But if the maximum working speed limit is 300rpm, when external input signal is 2.5V, the motor speed will be 300 rpm. The input signal over 2.5V, the motor speed maximum is 300rpm.

4.9 Flow Rate Calibration Interface

Flow Rate Calibration Interface as below:

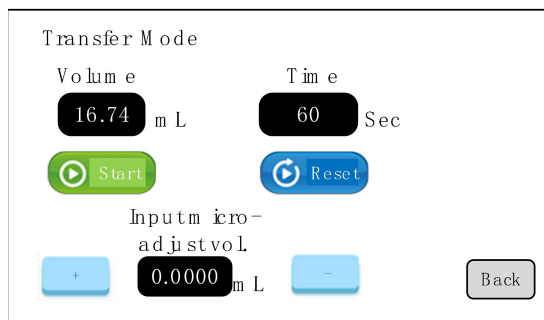

The function currently being calibrated is displayed in the upper-left corner of the calibration interface. When Volume is enabled, “Quantitative Measurement” is displayed. When liquid volume dispensing is enabled, “Liquid Volume Dispensing” is displayed. At all other times, “Transfer Mode” is displayed.

If liquid volume dispensing turned on, the target volume and running time are set up parameter, and unable to amend. Other modes, the running time is 60s, you can click the run time button to amend the running time.

Before the pump works, need to calibrate the flow rate to ensure the transferring or dispensing accuracy.

Transfer Mode or Volume Mode Operation Process as below:

- 1) After entering this interface, the test time defaults to 60 seconds, and the actual liquid volume defaults to the volume calculated based on the currently set flow rate.
- 2) Press the Start button to begin motor operation and start the calibration. At this point, the button turns gray.
- 3) When the running time is up, the system automatically stops and a numeric keypad for entering the measured liquid volume pops up. After entering the measured liquid volume and clicking the “Confirm” button, a “Calibration Complete” dialog box appears, indicating that the calibration is finished.
- 4) During the operation, clicking the Start button again can stop this calibration process.
- 5) The restore calibration function works as follows: Click the “Reset” button, and a prompt dialog box will appear. This allows you to restore the calibration coefficients

Note: The calibration process ensures that the flow rate remains unchanged by recalculating the speed (RPM).

Liquid Volume Dispensing Modes Operation Process:

- 1) In the liquid volume allocation mode, after entering this interface, the test time (flow rate) and actual liquid volume default to the current parameter values set



for liquid volume allocation.

- 2) Press the Test button to begin motor operation and start the calibration. At this point, the button turns gray.
- 3) After peristaltic pump stopping, a numeric keypad for entering the measured liquid volume pops up. After entering the measured liquid volume and clicking the “Confirm” button, a “Calibration Complete” dialog box appears, indicating that the calibration is finished.
- 4) During the operation, clicking the Test button again can stop this calibration process.
- 5) The restore calibration function works as follows: Click the “Restore” button, and a prompt dialog box will appear. This allows you to restore the calibration coefficients.

Note: 1) When the correction factor is changed, all parameters need to be recalculated. This may result in unreasonable rotational speeds for certain functional parameters. To prevent this from happening, it is recommended to reset the parameters after modifying the operating mode.

- 2) In speed dispensing mode, calibration is not required.

Micro Adjust Volume Process:

- 1) Entering the micro-adjustment volume the liquid volume input box.
- 2) Click the + or - buttons for the liquid volume to achieve the purpose of fine-tuning and calibration.

External Control Speed Mode Operation Process:

When the interface displays the external control speed adjustment function, only the “Increase” and “Decrease” buttons are effective. These can be used to fine-tune and calibrate the analog speed adjustment.

4.10 Common Mode Interface

Common mode interface as below:

Pum p head	Tube	D isp. Vol (m l)	D isp. Tim e (s)	Pause Tim e (s)	Suck Back (°)
YZ1515x	14#	2	1	2	0
YZ1515x	16#	7	1	2	0

« »

Click **System Settings** button in main interface, click **Common Mode** button (In all operating modes except for the liquid volume dispensing mode, this button is disabled.), enter **common mode** interface.

Add button: Click this button to increase one common mode. In dispensing mode, click Add button, it comes out a window ask whether add the current setting into common mode. Click “Yes”, then add this mode into common mode. Maxim can save 60 common modes.

Delete button: Select a common mode, then click the delete button. A confirmation dialog box will pop up asking if you want to delete it. Click “Yes” to delete this mode.

Clear button: Click this button to bring up a confirmation dialog box asking if you want to clear all modes. Click “Yes” to clear all modes..

OK button: Select a stored mode from the list, then click the “Confirm” button. The system will return to the main interface, and the dispensing parameters will be set to the parameters of the selected common mode.

Cancel button: Click this button back to main interface.

<< >>: Can check previous page or next page common mode.

4.11 Date & Time Interface

Date & Time Interface as below:

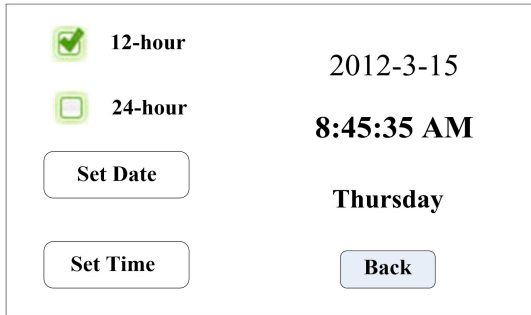

12-hour 2012-3-15
 24-hour **8:45:35 AM**
Thursday
 Set Date Set Time Back

This interface allows you to set the current date and time, which will be displayed in the upper-right corner of the main interface. Clicking the “**Set Date**” button brings up the numeric keypad for setting the year, with a valid range from 1970 to 2099. After entering the year, click the “**OK**” button to proceed to the month setting keypad, followed by the day setting keypad. Clicking the “**Set Time**” button brings up the numeric keypad to set the hours, minutes, and seconds in sequence.

4.12 Fixed Volume Measurement Interface

Fixed Volume Measurement Interface as below:

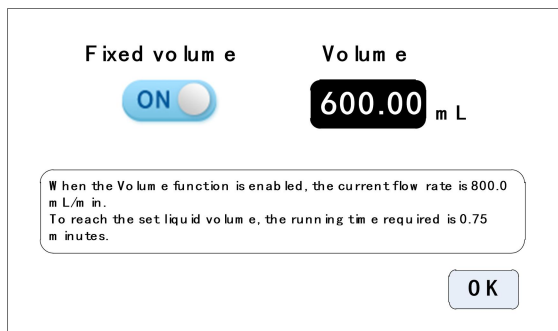

Fixed volume **Volume**
 ON **600.00** mL
 When the Volume function is enabled, the current flow rate is 800.0 mL/min.
 To reach the set liquid volume, the running time required is 0.75 minutes.
 OK

After enabling this function, the peristaltic pump will automatically measure the total liquid volume transferred. Once the liquid volume reaches the set value, the pump will stop automatically. During this process, the flow rate can be adjusted

freely as needed.

Click the **Fixed Volume** button and set it to **ON** to activate this function. Then, click on **Set Volume** to enter the desired liquid volume. The unit can be selected as either mL or L, with a range from 0.01 mL to 9999 L. A prompt box will display the estimated time required to reach the set liquid volume at the current flow rate. The maximum allowable time is 9999 minutes. If the calculated time exceeds 9999 minutes, the system will issue a warning notification.

4.13 Dispensing Interface

Volume Dispensing Interface as below:

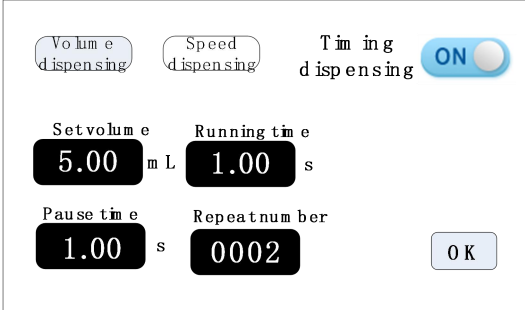

The screenshot displays the Volume Dispensing Interface with the following settings:

Volume dispensing	Speed dispensing	Timing dispensing
Set volume	Running time	<input checked="" type="checkbox"/>
5.00 mL	1.00 s	
Pause time	Repeat number	
1.00 s	0002	
<input type="button" value="OK"/>		

On the main interface, click the Dispensing button to enter the liquid volume dispensing settings interface. First, enable the liquid volume dispensing function before entering other parameters. After all parameters have been entered, click the **OK** button to return to the main interface.

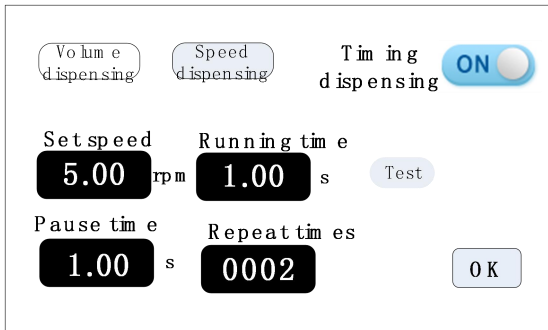
Speed Dispensing Interface as below:

On the main interface, click the Dispensing button to enter the speed dispensing interface. First, the speed dispensing function must be enabled before entering other parameters. After entering parameters such as dispensing speed and running time, you can click the Test button. The motor will run once according to the current speed and running time settings. After completing the parameter setup, click the OK button to return to the main interface.

4.14 Timer Start and Stop Interface

Timer Start and Stop Interface as below:

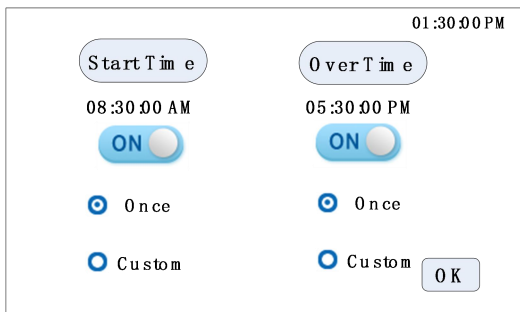

This function allows you to freely set the pump's start and stop times. When the current time reaches the preset time, the motor will automatically start or stop.

However, when either the Fixed volume measurement or timed dispensing function is enabled, the timer end function will be disabled.

5. Main Functions Operation Process

5.1 Flow Rate Transferring Function

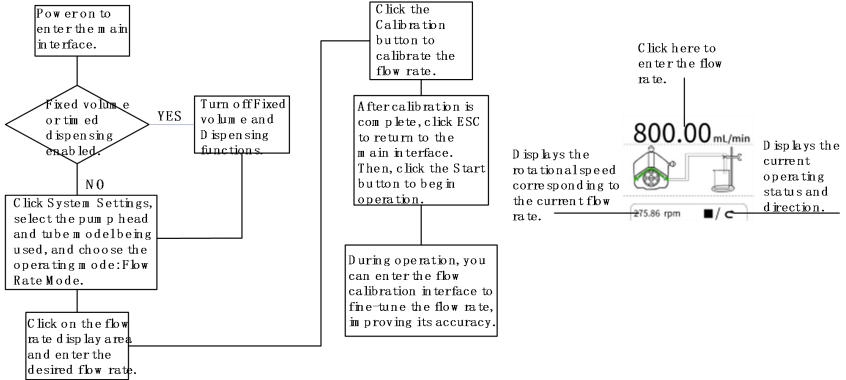

Note: Please refer the flow rate calibration interface instruction for flow rate calibration process.

5.2 Fixed Volume Measurement Function

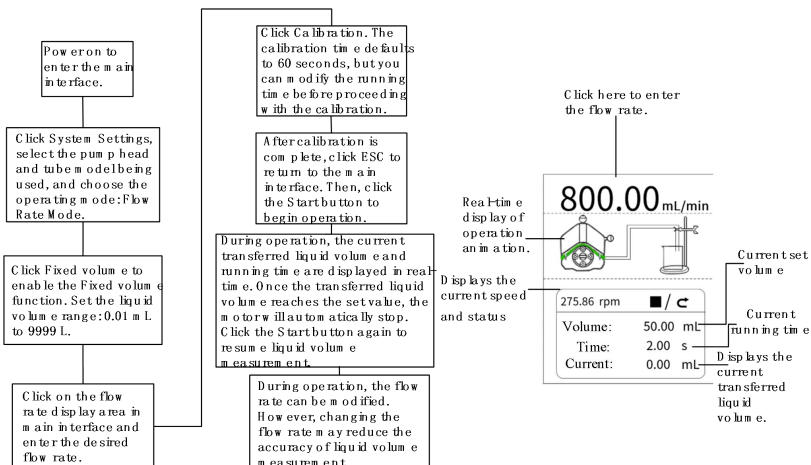

Note: Please refer the flow rate calibration interface instruction for flow rate calibration process.

5.3 Volume Dispensing

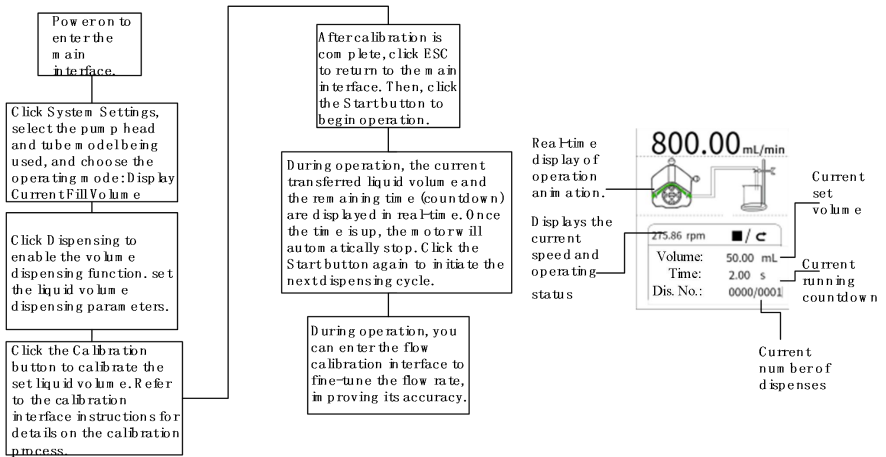

Note: Please refer the flow rate calibration interface instruction for flow rate calibration process.

5.4 Speed Dispensing

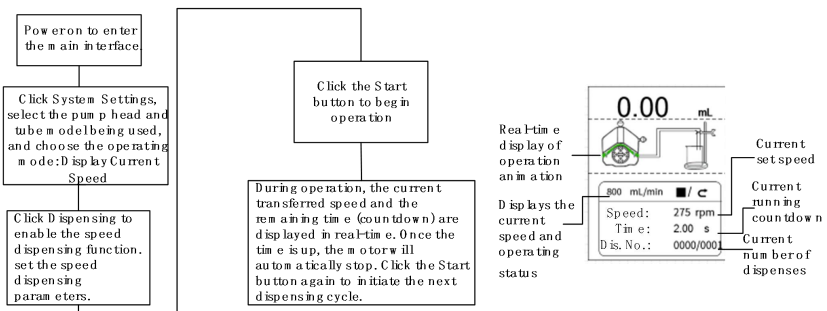

5.5 Timer Start And Stop Function

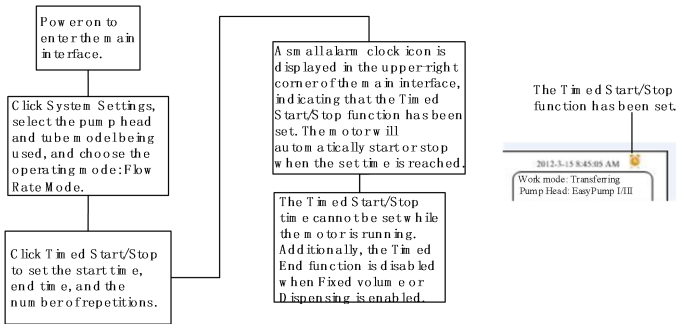

Under the flow rate transferring mode, set the pump start at 8:30 a.m. from Monday to Friday, stop at 5:30 p.m., the process as below:

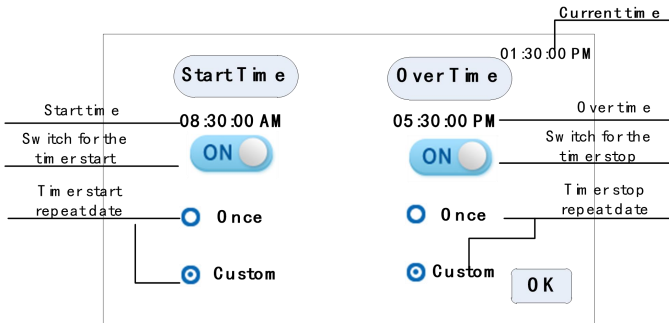

Click on the Start Time to set the timed start time to 8:30. Then, click the Switch for the timer start to turn it ON. Next, click on the Custom option, which will bring up a window to set the repeat dates. Configure the settings as follows:

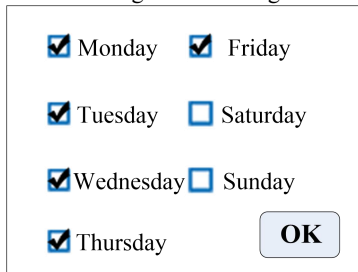

Monday Friday

Tuesday Saturday

Wednesday Sunday

Thursday

OK

6. External Control Interface Instruction

External control interface is as shown below

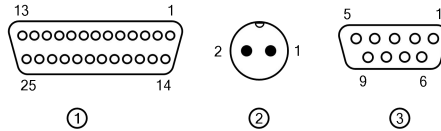

① DB25 external control connector instruction

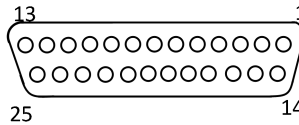

Pin	Pin Definition	Explanation	Note
1	0-5V	0V to 5V voltage signal input terminal	Analog signal input terminal
2	0-10V	0V to 10V voltage signal input terminal	
3	4-20mA	4-20mA current signal input terminal	
4	I_V_	Analog signal negative terminal	
5	/	/	/
6	R/S1	External control start/stop signal with passive signal input	The passive switch or foot pedal switch can be connected with the terminal. Set the validity of this input in external setting interface--foot pedal option.
7	R/S2	External start/stop signal input	Active signal 5-24VDC input

8	NC	External full speed signal input	Active signal 5-24VDC input
9	CW/CCW	External direction signal input	Active signal 5-24VDC input
10	/	/	/
11	/	/	/
12	/	/	/
13	/	/	/
14	/	/	/
15	/	/	/
16	OUT1	Operating status output terminal 1	Open collector output
17	OUT2	Operating status output terminal 2	/
18	COM	Provides voltage for logic outputs	External power supply negative
19	GD2	Connected to the internal GD1	/
20	/	/	/
21	/	/	/
22	/	/	/
23	+5V	Internal 5V output positive terminal	Internal 5V output
24	GD1	Internal 5V output negative terminal	
25	0V	Connected internally to GD1 and GD2	

External control wiring and function description

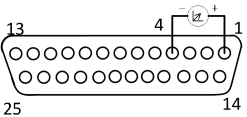
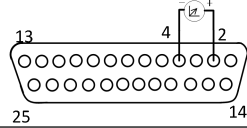
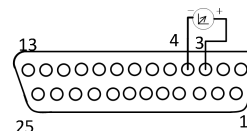
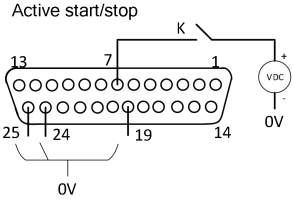
Signal and wiring	Function description	
<p>Analogue: 0-5V</p> 	<p>Analogue signal input terminal: Choose the External speed control signal and turn on the Ext. Speed in external control setting interface, control the motor speed from 0 rpm to maximum speed through analogue signal.</p> <p>Notice: Please do not connect 0-10V signal to 0-5V terminal or 4-20mA input terminal. This is forbidden. Wrong connection may damage the pump.</p>	
<p>Analogue: 0-10V</p> 		
<p>Analogue: 4-20mA</p> 		
<p>Active start/stop</p> 	<p>In Pulse mode: Short circuited K then disconnect, the motor starts running. Short circuited and disconnect again, motor stops running.</p> <p>In Level mode: Short circuited K, the motor starts running, disconnect K, motor stops running.</p>	<p>In the external control settings interface, configure the external control method, enable the corresponding external control function, and</p>

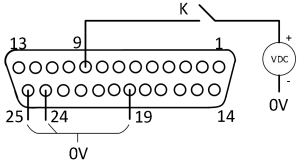
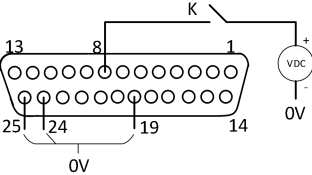
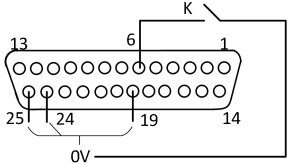
<p>Active direction</p> 	<p>In Pulse mode: Short circuited and then disconnect K once, the motor changes working direction once.</p> <p>In Level mode: Short circuited K, motor runs clockwise, disconnect K, motor runs anticlockwise.</p>	<p>ensure that the external control signal input is active.</p> <p>The wiring here is an external active signal, and customers can choose to</p>
<p>Active full speed</p> 	<p>In Pulse mode: Short circuited K, the motor will run with full speed; Disconnect it, the motor stops.</p> <p>In Level mode: no full speed.</p>	<p>use the +5V output from pin 23 for their own use.</p>
<p>Passive start/stop</p> 	<p>In Pulse mode: Short circuited K then disconnect, the motor starts running; short circuited K and disconnect again, motor stops running. (Under transferring modes, current working has been stopped. Under fixed volume measurement mode and timed dispensing modes, current working has been paused. Disconnect after short circuit again, it will continue to work);</p> <p>In Level mode: short circuited K, motor starts running, disconnect K, motor stops running.</p>	

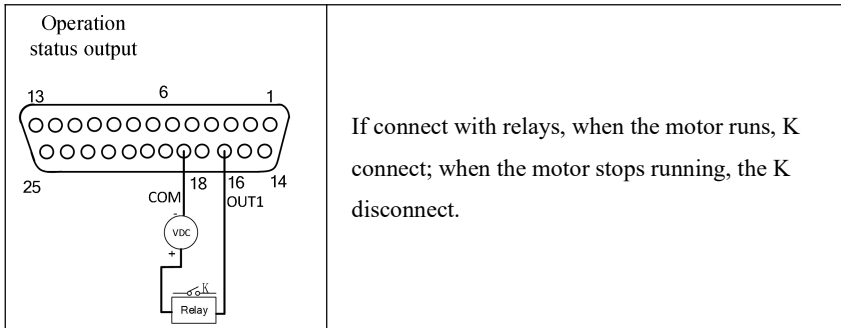

② XS6 Connector



Pin	Pin Definition	Explanation	Note
1	R/S1	External control start/stop signal with passive signal input	The passive switch or foot pedal switch can be connected with the terminal. Set the validity of this input in external setting interface--foot pedal option.
2	GD1	Internal 5V output negative terminal	/

③ DB9 Connector

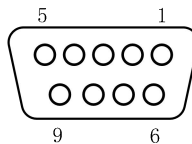

Pin	Pin Definition	Explanation	Note
1	/	/	/

2	RS232-TXD	Signal transmitted by peristaltic pump, received by upper computer	Choose RS232 in the Communication setting interface, this terminal is active.
3	RS232-RXD	Signal received by peristaltic pump, transmitted by upper computer	
4	/	/	/
5	GND	Communication ground port	
6	/	/	/
7	GND1	RS485 signal ground	
8	RS485-B	Connect RS485 B- terminal	Choose RS485 in the communication setting interface, this terminal is active.
9	RS485-A	Connect RS485 A+ terminal	

Communication wiring and function description

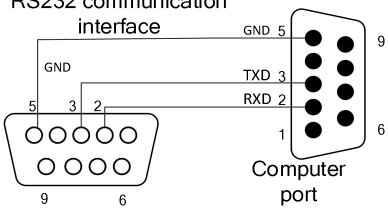
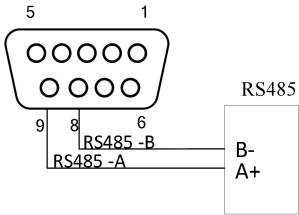
Signal and wiring	Function description
<p>RS232 communication interface</p> 	<p>RS232 communication interface: Choose RS232 in the communication setting interface, this terminal is active.</p>
<p>RS485 communication interface</p> 	<p>RS485 Communication Interface: Choose RS485 in the Communication setting interface, this terminal is active.</p>

7. Technical Specification

Flow rate resolution	0.01ml/min	Power supply	AC 220V±10% 50Hz/60Hz(standard) AC 110V±10% 50Hz/60Hz(optional)
Operation mode	Touch screen and mechanical keypad	External control	Switch signal
External speed control	0-5V, 0-10V, 4-20mA for option	External control	Passive switching signal: Foot pedal switch Active switching signal: 5-24V universal
Temperature	0-40°C	Relative humidity	<80%
Communication	RS232/RS485	Output port	Output motor running status(Open collector output)
Back suction angle	0-360°	Protection rate	IP31
Speed range	V6-3L/V6-6L/V6-12L	0.1-600rpm	
Power consumption	V6-3L	<80W	
	V6-6L	<180W	
	V6-12L	<300W	
Motor type	V6-3L/V6-6L/V6-12L	Closed loop stepping motor	

8. Main Functions and Features

8.1 4.3 inch color touch screen control, animation shows working state, the flow volume and motor speed are displayed in the same screen.

8.2 Intelligent calibration function, it can calibrate the flow rate and dispensing volume, ensure the flow accuracy, suitable for high accuracy transferring liquid.

8.3 On-line micro adjusting function, it can adjust the flow rate during production progress, to avoid the filling errors because of tubing fatigue and elasticity decreased.

8.4 Accurate angle control technology, reach high precision dispensing and measurement.

8.5 Fixed volume measurement function: After turning on this function, the peristaltic pump will measure the liquid volume automatically, it will stop automatically after the volume reaches the set value. During this process, the flow rate can be changed. It is suitable for liquid metering in the laboratory or quantitative feeding in the chemical reaction process, etc.

8.6 Fixed time and volume function: After turning on this function, the peristaltic pump will transfer fixed volume within set time. It is suitable for liquid dispensing in laboratory and industrial production.

8.7 Timer start and stop function: Can set the pump start and stop time freely, reach automation control.

8.8 Power down memory function, store the running parameters in time, safe and reliable.

8.9 Fast fluid-filled function, can wash the tubing and also fill liquid into tubing.

8.10 High torque and low power loss, it can load several pump heads or multichannel pump head, meet different application requests.

8.11 External control start and stop, convenient for equipment supporting.

8.12 304 stainless steel shell, anti-corrosion, in line with industrial requirements. Anti-interference, can shield the interference signal.

9. Dimension Drawing

Unit: (mm)

V6 series product

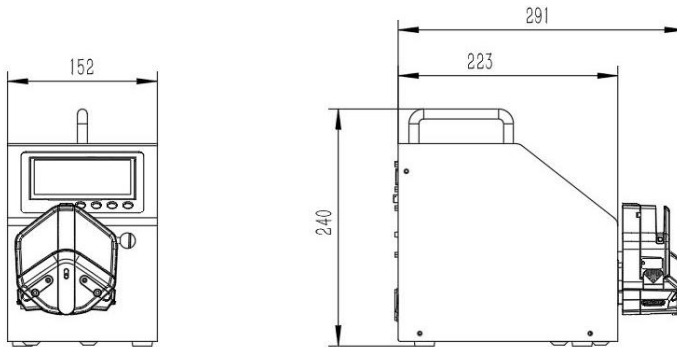

V6-3L series + EasyPump Pump Head

Note: For each additional pump head in series, the longitudinal dimension shall be increased by 61mm.

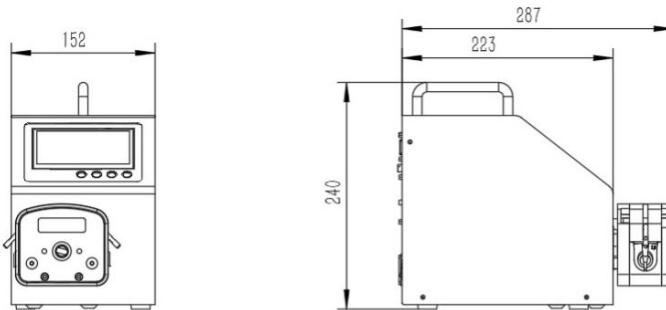

V6-3L Series + DZ25-3L Pump Head

Note: For each additional pump head in series, the longitudinal dimension shall be increased by 60mm.

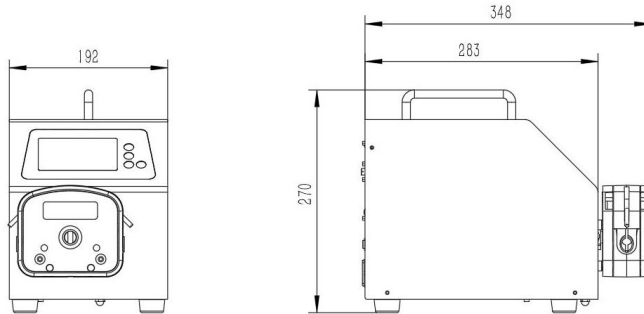

V6-6L Series+DZ25-6L Pump Head

Note: For each additional pump head in series, the longitudinal dimension shall be increased by 60mm.

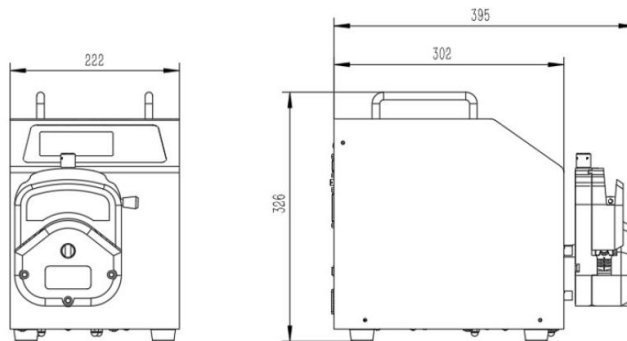

V6-12L Series +YZ35 Pump Head

Note: For each additional pump head in series, the longitudinal dimension shall be increased by 78mm.

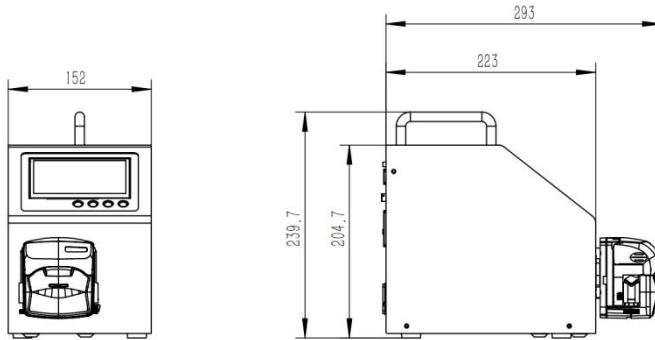

V6-3L+KD pump head

Note: For each additional pump head in series, the longitudinal dimension shall be increased by 63mm..

10. Maintenance

- Verify the pump current operational status before turning on power. Operate only under normal conditions.
- Inspect for fluid leakage and promptly address any potential faults.
- Clean any spilled liquid around the pump promptly.
- If liquid splashes on the pump, turn off and unplug the power supply, check for internal leakage, and contact the manufacturer if liquid has entered the equipment
- Ensure that the foot pedal switch and other external control plugs are connected or disconnected only when the power is off, to prevent damage.
- The power socket should be equipped with a ground wire and properly grounded.
- This product is not designed to be waterproof. Operators are advised to implement appropriate protective measures when operating in wet environments.
- This product is not equipped with special certifications, such as medical



certification. For applications in specialized fields like medical or military, users are responsible for conducting their own certification/validation.

- If the product will not be used for an extended period of time, please clean it thoroughly and store it in a dry, well-ventilated area.
- The company is not liable for any losses resulting from product malfunctions or misuse of the product.

11. Warranty and After-Sales Service

A three-year warranty is provided for the pumps, with certain exceptions outlined below. The company is not responsible for any loss, damage, or expenses that are directly or indirectly associated with the use of its products. The warranty does not require the company to cover costs related to removal, installation, transportation, or other charges incurred in connection with a warranty claim.

If a pump fails within the warranty period, and the issue is confirmed by the company's technical department, spare parts will be supplied at no additional charge. Shipping costs must be covered by the customer.

Warranty Exceptions:

- The warranty does not cover repairs or service needed due to normal wear and tear, or insufficient maintenance.
- Tubing and pumping accessories, classified as consumable items, are not included under warranty.
- Failures caused by electrical surges are excluded from coverage.
- Damage resulting from chemical exposure is excluded.
- Failures due to improper operation or intentional damage are not covered.

Innofluid Co., Ltd.

Add: Building 10, No. 860, Xinyang Road, Lingang New Area, Pilot Free Trade Zone, Shanghai, China.

Manufacturer: Baoding Shenchen Precision Pump Co., Ltd.

Tel: 0086-312-5958380

Fax: 0086-312-6780636

Website: www.innofluid.com

Email: info@innofluid.com

MADE IN CHINA